

## e-l-m Wireless

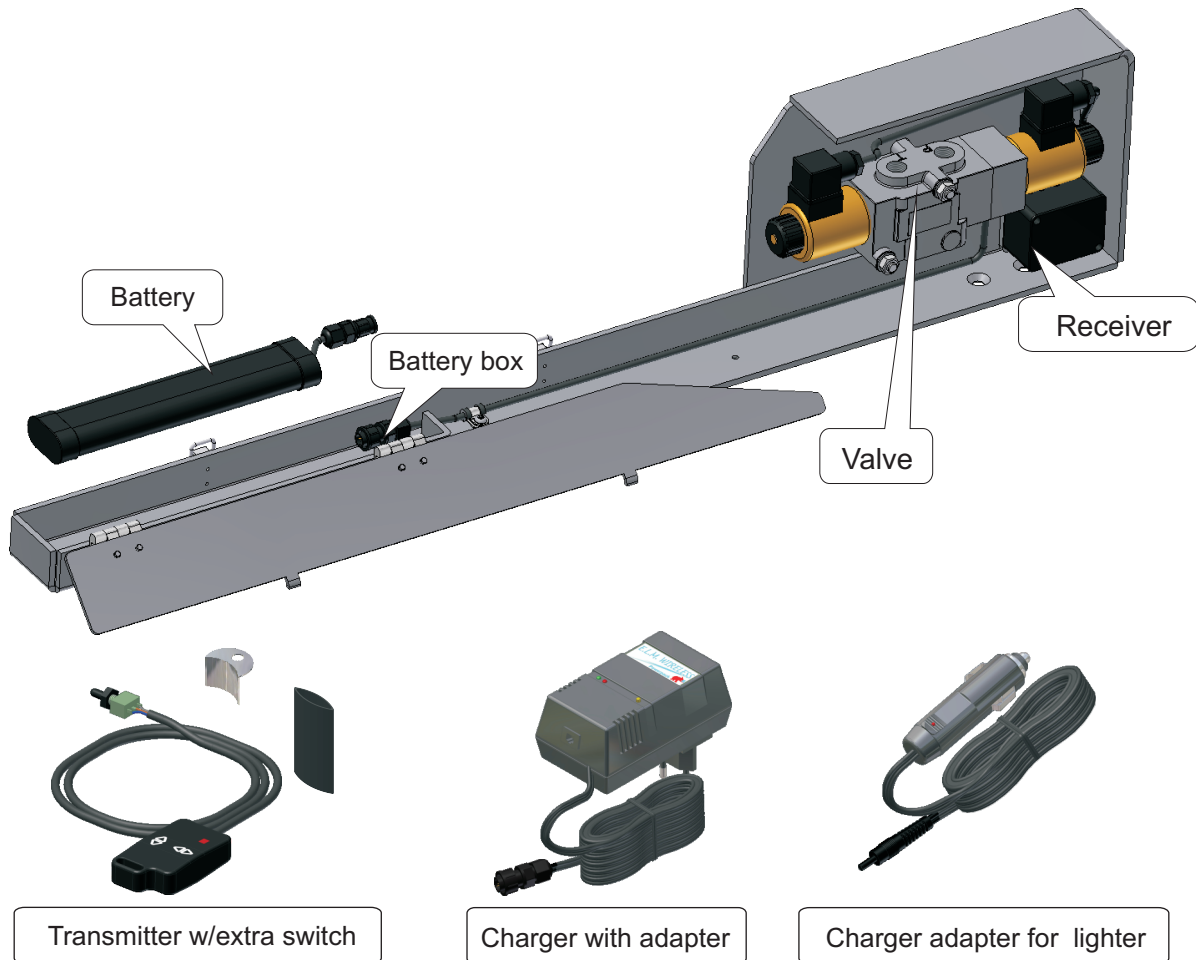

### Advantages

- Add an extra hydraulic function without extra hoses and wires, **for limited means**
- 3<sup>rd</sup> and 4<sup>th</sup> function at the attachment
- Ready for the use - directly from e-l-m.
- Operated by hand sender or switch options
- A cost effective solution relating to price and space





Technical data:

- 2-channel receiver
- Highly secure  protocol
- Led indication of transmission
- Power saving auto shutoff feature
- 12V DC
- 433 Mhz version  compliant for use in Europe
- Possibility to use until 12 hand senders per receiver
- 100% waterproof
- Rechargeable batteries in the receiver

